



Pony Testing International Group

报告编号(Report ID): MZIRLCYN02502747

锂电池跌落测试报告

Lithium Battery Drop Test Report

Sample Description & Model	Lithium-ion Rechargeable Cell FST 18650 2000mAh
Applicant	First New Energy Group Co., Ltd
Manufacturer	First New Energy Group Co., Ltd

P O N Y 谱尼测试
Pony Testing International Group
www.ponytest.com

No.: MZIRLCYN02502747

Code: oxc23y0gh



Pony Testing International Group

I. SAMPLE DESCRIPTION

Sample Description	Lithium-ion Rechargeable Cell	Sample Model	FST 18650 2000mAh
Applicant	First New Energy Group Co., Ltd		
Manufacturer	First New Energy Group Co., Ltd		
Nominal Voltage	3.6V	Rated Capacity	2000mAh
Outer package	Paper Box	Inner package	Plastic Bag
Dimensions	115×74×67mm	Cushion	Paper Card
Gross weight	0.50kg	Battery number	8Pcs/packing
Entrush date	2015-10-29	Finished date	2015-11-04
Packaging type	Package including lithium batteries.		

II. REFERENCE METHOD

《Recommendations On The Transport Of Dangerous Goods-Model Regulations》
(ST/SG/AC.10/1/Rev.18)

III. TEST ITEM

1.2m Drop test
Gross Weight Measure

IV. CONCLUSION

This package is capable of withstanding a 1.2m drop test in any orientation without damage to cells or batteries contained therein, without shifting of the contents so as to allow battery to battery contact and without release of contents. The weight of the package is 0.50kg gross mass.

Prepared by: *zhaojunjun* Checked by: *zfc* Approved by:

Issue Date: November 4, 2015

tome



Pony Testing International Group

V. TEST METHOD

《Recommendations On The Transport Of Dangerous Goods-Model Regulations》(Rev.18)

Special Provision 188 of Chapter 3.3.

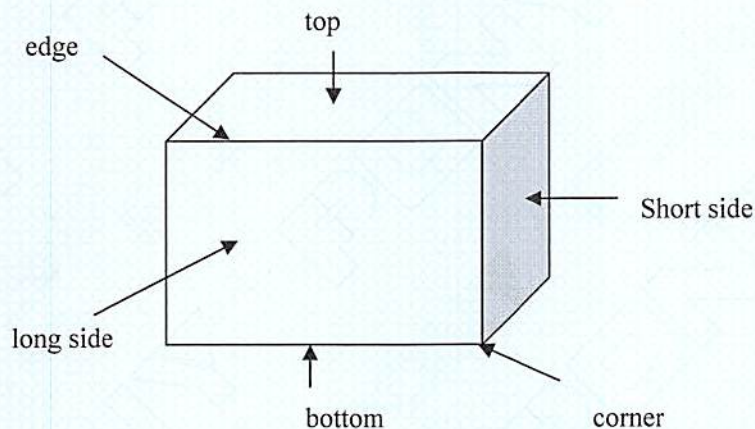

VI. TEST APPARATUS

IE-0279 Drop test system

IE-0178 BALANCE

VII. TEST ENVIRONMENT CONDITION

Ambient temperature: 20~25 (°C)

Ambient humidity: 50~60 (%)

VIII. TEST DATA

1.2m Drop test	Side	Edge	Angle
Test Result	a. Without damage to cells or batteries contained therein; b. Without shifting of the contents so as to allow battery to battery (or cell to cell) contact; c. Without release of contents.		
Conclusion	The test package is capable of withstanding a 1.2m drop test in any orientation.		



Pony Testing International Group

Test Item	Gross Weight Measure
Test Result	0.50kg
Conclusion	Passed

IX. PHOTO OF THE SAMPLE

Battery

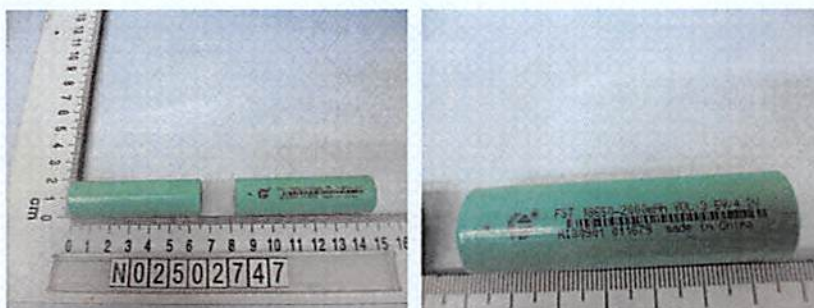

Package



Authenticate the photo on original report only

*** End of report ***